



CATERPILLAR

631D Wheel Tractor-Scraper

Summary of features

- 21 cu. yd./16.1 m³ capacity (struck) . . . 31 cu. yd./23.7 m³ heaped.
- Cat Model 3408 diesel Engine, turbocharged and aftercooled to pack more air into the cylinders, provides 450 flywheel horsepower/336 kW . . . and 1,099 cu. in./18.0 liters displacement.
- Eight forward speeds up to 31 MPH/49.9 km/h with Cat semi-automatic power shift transmission.
- Cushion hitch absorbs haul road shocks . . . for higher usable speeds over rough terrain, less machine loping, faster cycle times, lower maintenance costs, longer machine life.
- Double-acting hydraulics supply positive cutting edge penetration, apron closure and material ejection.
- 90° steering both left and right, with ROPS . . . for maximum maneuverability.
- Differential lock . . . rigidly connects both drive wheels for positive traction.
- Servicing ease . . . easy access . . . localized service area . . . independent removal of major components.
- CAT PLUS services . . . from your Caterpillar Dealer . . . the most comprehensive, total customer support system in the industry.



Model shown may have optional equipment.



Caterpillar Engine

Flywheel power @ 2000 RPM 450 HP/336 kW (Kilowatts (kW) is the International System of Units equivalent of horsepower.)

The net power at the flywheel of the vehicle engine operating under SAE standard ambient temperature and barometric conditions, 77°F/25°C and 29.63" Hg/100 kPa, using 35 API gravity fuel oil at 60°F/15.6°C and after deductions for fan, air cleaner, water pump, lubricating oil pump, fuel pump, alternator and muffler. No derating required up to 7,500 ft./2287 m altitude.

Caterpillar four-stroke-cycle 3408 turbocharged diesel Engine, 65° V-8 with 5.4"/137 mm bore, 6.0"/152 mm stroke and 1,099 cu. in./18.0 liters displacement.

Direct injection Cat fuel system with individual, adjustment-free injection pumps and valves, and variable injection timing.

Jacket water aftercooled. Integral inlet manifold porting with two intake and two exhaust valves per cylinder. Valves are actuated by a pushrod mechanism. Single camshaft is mounted in "V" of engine. 24-volt direct electric starting system. Ether starting aid for cold weather is standard.

631D

Wheel Tractor-Scraper



transmission

Cat eight-speed semiautomatic powershift with single-lever shift control. All shifts up or down from 2nd to the gear selected are automatic. Upshifting is limited to speed selected by control lever. Reverse, 1st and 2nd are manually controlled. A foot control holds transmission in any gear. Standard downshift inhibitor helps prevent engine overspeed due to improper downshifts.



differential control

Cat differential lock, engaged by foot pedal, positively prevents either drive wheel from spinning free in poor traction conditions. Allows normal differential action when not engaged.



final drives

Compact planetary design and full-floating axles, independently removable from wheel mounting. Service-free, double-row roller bearings. Assemblies protected with Duo-Cone® floating ring seals.



steering

Two double-acting hydraulic cylinders. Hydraulic follow-up system for automotive feel. Positive, well-modulated flow control for constant steering response. Full 90° right or left, unrestricted by ROPS.

Width required for curb-to-curb turn 40'1"/12.216 m



brakes

(System meets OSHA regulations)

Service brakes are air-applied, spring-released, cam operated expanding shoe type. Mounted on each wheel, two per axle.

Parking — Uses service brakes. Spring-applied, air released. Apply manually with button on dash.

Emergency — Uses service brakes. Spring-applied, air released. Can be applied with button on dash. If service air pressure drops to 60 psi/2.07 bar/206 kPa, audible and visual alarms warn operator. Brakes apply automatically when air pressure drops to 40 psi/2.76 bar/276 kPa.



tires

Productive capabilities of the 631D are such that, under certain job conditions, Ton-MPH/tkm/h capabilities of standard or optional tires could be exceeded and therefore limit production. Caterpillar recommends the user evaluate all job conditions in order to make proper tire selection. Consult tire manufacturer for specific data.

Standard for tractor and scraper:
Conventional, 33.25-35, 38 PR (E-3)

Optional for tractor and scraper:
Conventional, 37.25-35, 30 PR (E-3)
Radial steel cord, 33.25-35



cushion hitch and gooseneck

Parallelogram-type linkage connects two-piece hitch. Vertically mounted hydraulic cylinder transfers road shocks to two nitrogen accumulators. Controlled oil flow dampens "rebound" oscillation. Leveling valve automatically centers piston in cylinder for all scraper loads. Cushion ride lockout control retains positive cutting edge down-pressure for scraper loading and fill spreading. Cushion hitch makes extensive use of steel castings, eliminating many welded joints. Double kingbolt design withstands high external forces, allows easy installation and removal. Box-section gooseneck reduces plate and weld stresses. One-piece fabricated draft tube and wide-mounted bowl lift cylinders reduce stress in draft frame.



service refill capacities

	U.S. Gallons	Liters
Fuel tank	200	757
Lubricating systems:		
Crankcase	12	45
Transmission	33.5	127
Differential	36	136
Final drive—each side	11	42
Cooling system	37	140
Total hydraulic system (steering and scraper)	90	341



weight (approximate)

Weight Distribution:

Shipping — with ROPS canopy and 10% fuel

	Lb	Kg
Front axle—68.2%	62,660	28 422
Rear axle—31.8%	29,260	13 272
Total	91,920	41 694

Operating — with ROPS canopy, full fuel tanks, and operator

	Lb	Kg
Empty		
Front axle—68.9%	64,320	29 175
Rear axle—31.1%	29,050	13 177
Total	93,370	42 352

Loaded — based on 75,000 lb/32 020 kg rated load

	Lb	Kg
Front axle—53.5%	90,120	40 878
Rear axle—46.5%	78,250	35 493
Total	168,370	76 371



capacity

Rated load	75,000 lb./34 020 kg
Heaped, SAE rating	31 cu. yd./23.7 m ³
Struck, SAE rating	21 cu. yd./16.1 m ³

Reliable Cat power train — power you can depend on.

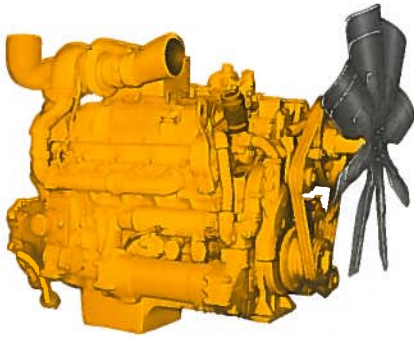

Reliability and durability... that's what you get from the 450 flywheel horsepower/336 kW Cat Model 3408 diesel, a 65° V-8. Turbocharged and jacket water aftercooled for efficient fuel combustion, the 3408 offers performance with serviceability, long component life, simplified rebuild procedures.

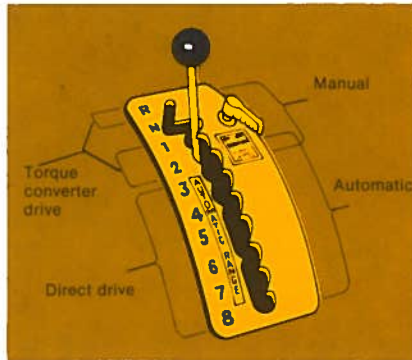

Cat 8-speed semiautomatic transmission combines automatic shifting with high torque multiplication and direct drive mechanical efficiency. Reverse, 1st, 2nd and the highest desired gear are manually selected. The transmission shifts up and down automatically between 2nd and the highest selected gear. Reverse and gears 1 and 2 are torque converter drive for powerful rimpull needed for loading and dumping. Gears 3 through 8 are direct drive for quick acceleration and high hauling speeds. A hydraulic governor monitors ground speed to control shifting between 2nd and the highest selected gear... reducing the possibility of lugging and overspeed. Downshift inhibitor, which helps prevent engine overspeed due to improper downshifts, is standard.

Built-in convenience, comfort



For a smoother, quieter ride, optional ROPS sound-suppressed cab is isolated — entirely secured on rubber mountings, with no metal-to-metal contact. Sound is further suppressed with insulated right and back walls, a roof headliner and positive seals on doors and windows.

Ventilation is provided by air vents in key areas to give maximum air flow, a side wing on the door and a sliding glass window on the right. An optional air conditioner is available.

Rugged equipment for the tough applications.

Strengthened for rock service:

Bowl

1. Bottom — top plate.*
2. Bottom — bottom plate.*
3. Side sheets.
4. Side bottom rails.*
7. Cutting edges.*
8. Cutting edge support.*
9. Router bit support.*

13. More cutting edge support ribs.
14. Router bits.
15. Router bit support reinforcement.
16. Side reinforcement plate.

Ejector

5. Front sheet.
6. Bottom rail.

Apron

10. Lip — channels.*
 11. Lip — large plate.*
 12. Apron front sheet.*
- *Heat treated.

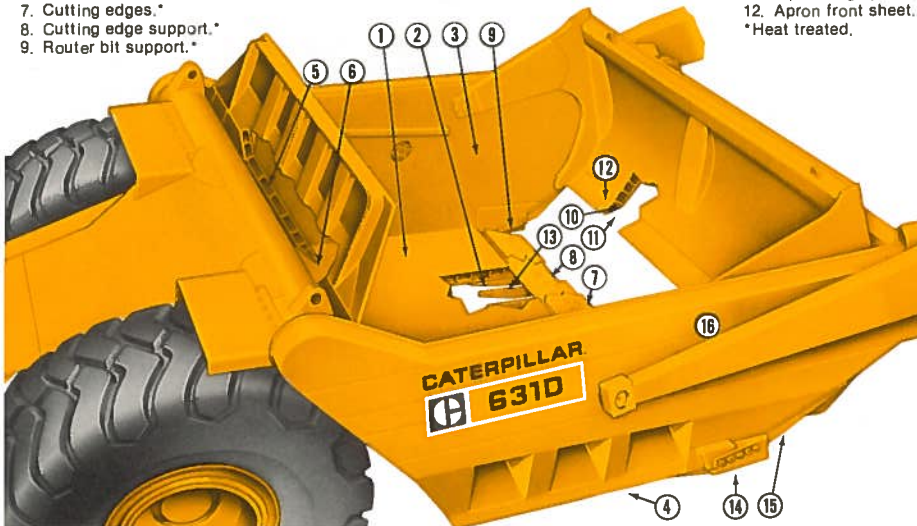

Large capacity and wide, low bowl design... coupled with low weight-to-horsepower... add up to excellent loadability, maximum loads and high productivity. Angle and height of ejector are designed for optimum load retention and material rolling action. And you get these time-proven features: positive bulldozing ejection, powerful double-acting hydraulics and cantilever-mounted wheels.

For rock application, a Special Application Scraper is available. Complete bowl is box sectioned for maximum strength, and high-tensile steel is used in high wear and stress areas. Extensive heat treatment is used in bowl bottom plates, side bottom rails, cutting edge support, router bit support and apron front sheet and lip.

More work time.

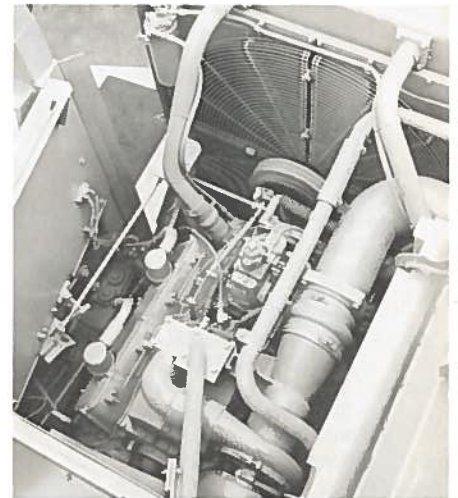

Servicing ease reduces downtime.

- Two-piece hinged hood and hinged door on left front of tractor offer easy access to engine.
- Independent removal of major components.
- Easily accessible hydraulic lines and wiring.
- Hydraulic tank mounted to the front of fuel tank on right front deck.
- Sight gauges for transmission and differential.
- Increased lubrication intervals — every 100 hours — for nearly all hitch and steering fittings.
- Push-button operation of air tank drains.

Additional protection mean more operator efficiency.

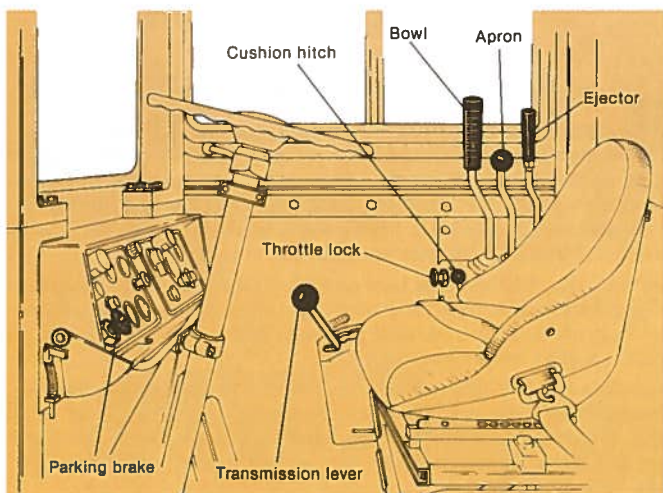

Convenient controls are designed to improve operator efficiency: Bowl-apron trigger control enables operator to position bowl and lower apron with one lever. Apron "float" and ejector "return" positions are detent-held to free operator's hand for other controls. Throttle lock (optional) holds throttle in high idle position during long hauls or when climbing grades. Emergency parking brake button control located on dash. Familiar location of transmission console and scraper controls at operator's right.

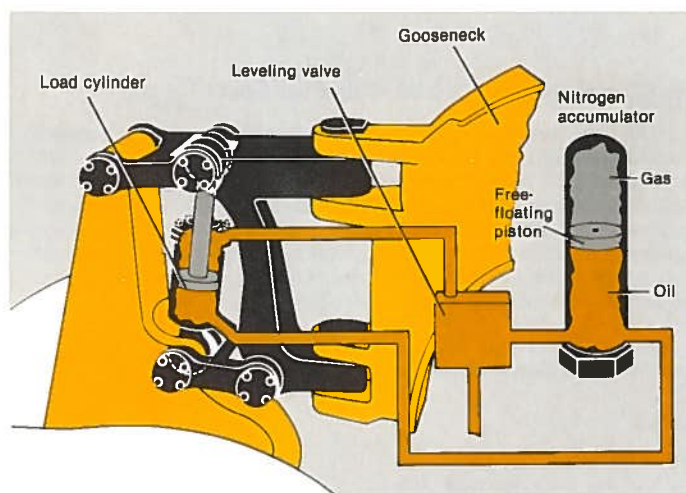

Cushion hitch provides smoother hauling and higher usable speeds. It connects two separate tractor and scraper castings at the top and bottom by mechanical links, forming a pivoting parallelogram arrangement which allows vertical movement between the two sections. A hydraulic cylinder connects the links from the bottom tractor pivot to the top scraper pivot. When the 631D hits a bump, the load cylinder forces oil into two nitrogen-over-oil accumulators. The accumulators cushion the bump like a shock absorber. The system can handle several shocks at the same time to reduce machine bounce. And that means greater productivity... longer machine life... reduced haul road maintenance... less operator fatigue.

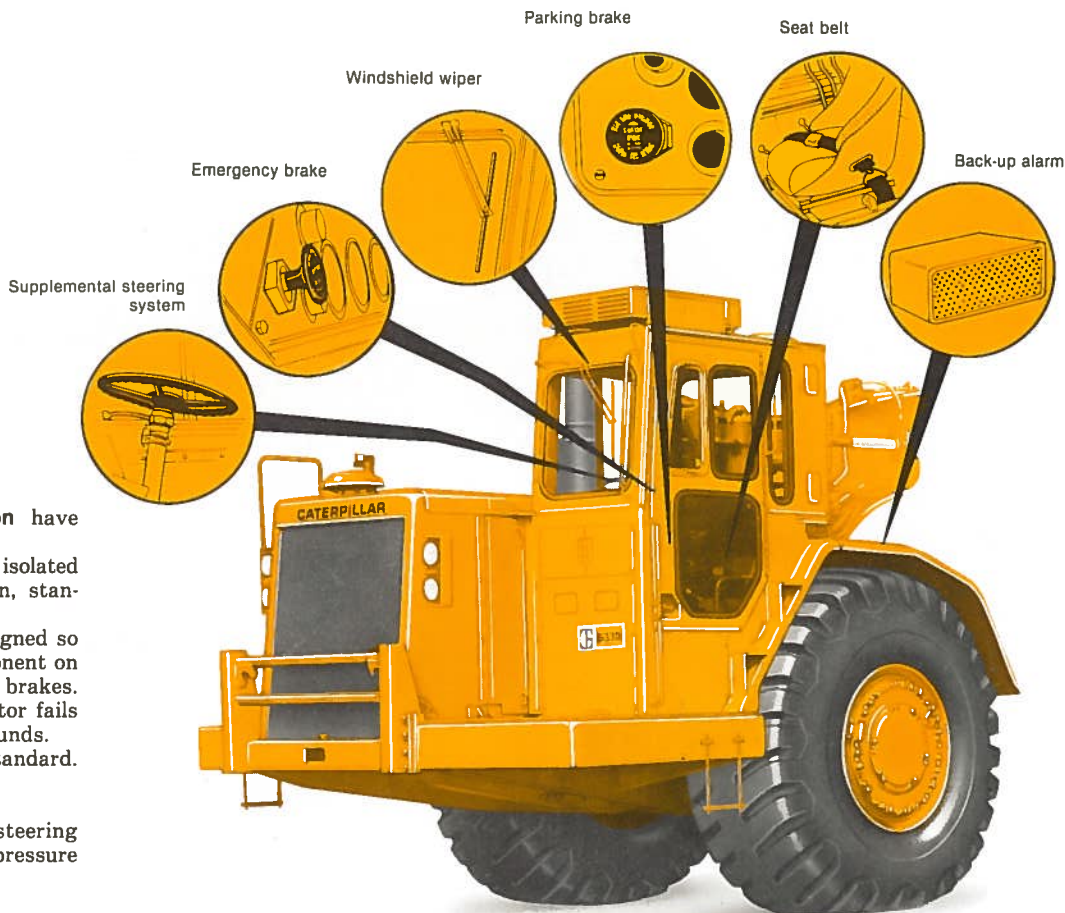

Machine and operator protection have been designed into the 631D: Integral ROPS canopy, vibration isolated for improved sound suppression, standard on machines sold in U.S.A. Emergency braking system designed so that no failure of a single component on the line will cause a total loss of brakes. Automatically actuates if operator fails to engage after warning horn sounds. Seat belt, windshield wiper are standard.

Additional options:

Ground-driven supplemental steering system... supplies hydraulic pressure for steering if engine stops. ROPS sound-suppressed cab.

er-
cks
nd"
der
ive
ng.
ng
er-
ion
ed
in

ers
57

45
27
36
42
40

41

22
72
94

75
77
52

78
93
71

g
3



design

Low and extra-wide scraper bowl is operated by high-speed hydraulics. Cutting edge near center of bowl for minimum material travel. Power-closing apron. Hydraulic dozer-type ejector. Reinforced box-section construction with extensive use of high-tensile-strength steel. Wide-mounted bowl lift cylinders. Minimum transporting width from inside-mounted apron arms and removable draft arms. Cantilever-mounted wheels with Lifetime-Lubricated bearings and Duo-Cone® Floating Ring Seals.



operating data

Maximum depth of cut	19"/483 mm
Width of cut (outside router bits)	11'5.5"/3.490 m
Cutting edge dimensions:	
Standard, center section	.88" x 16" x 62"/ 22 x 406 x 1570 mm
Each end section	.88" x 13" x 35"/ 22 x 330 x 900 mm
Optional, center section . . .	
available in thickness up to 1.62"/42 mm	
Each end section . . .	
available in thickness up to 1.62"/42 mm	
Maximum available hydraulic penetration force @ cutting edge (approximate), empty	
	48,000 lb./21 770 kg
Maximum depth of spread	16.7"/424 mm
Apron opening, bowl 6"/150 mm off ground level	
	6'7"/2.010 m
Apron closure force with cutting edge fully raised and apron opened 12" 300 mm, approximate	
	38,000 lb./17 240 kg



hydraulics

Bowl, apron and ejector individually controlled. Bowl lever has raise, hold, power down and quick-drop positions. Trigger on bowl lever allows simultaneous apron closure with bowl actuation. Apron lever has open, hold, positive close and detented float positions. Ejector lever has forward, hold and detented return positions. Automatic kickout on return.

Bowl uses two 7.2"/183 mm bore and 34.4"/870 mm stroke, double-acting cylinders with special quick-drop valves. Carry check valves isolate circuit from load in hold position. Wide, low bowl for large payloads and excellent loadability.

Apron uses one 8.2"/208 mm bore and 28.6"/730 mm stroke, double-acting cylinder with multiplier linkage controlling force, speed and length of travel. Closure force regulated by relief valve protecting apron and bowl. Sequence relief valve protects circuit when bowl is raised with apron closed.

Ejector uses one 8.2"/208 mm bore and 74"/1880 mm stroke, double-acting cylinder.

Hydraulic circuits are filtered closed systems. Single reservoir with separate pumps for scraper-steering control and cushion hitch:

Output @ 2000 RPM:

Steering	99 gpm/384 liters/min
Scraper	91 gpm/352 liters/min
Cushion hitch	16 gpm/63 liters/min

Relief valve setting:

Scraper	2000 psi/141 bar/13 790 kPa
Steering	1725 psi/121 bar/11 893 kPa
Cushion hitch	2300 psi/162 bar/15 858 kPa



dimensions (approximate)

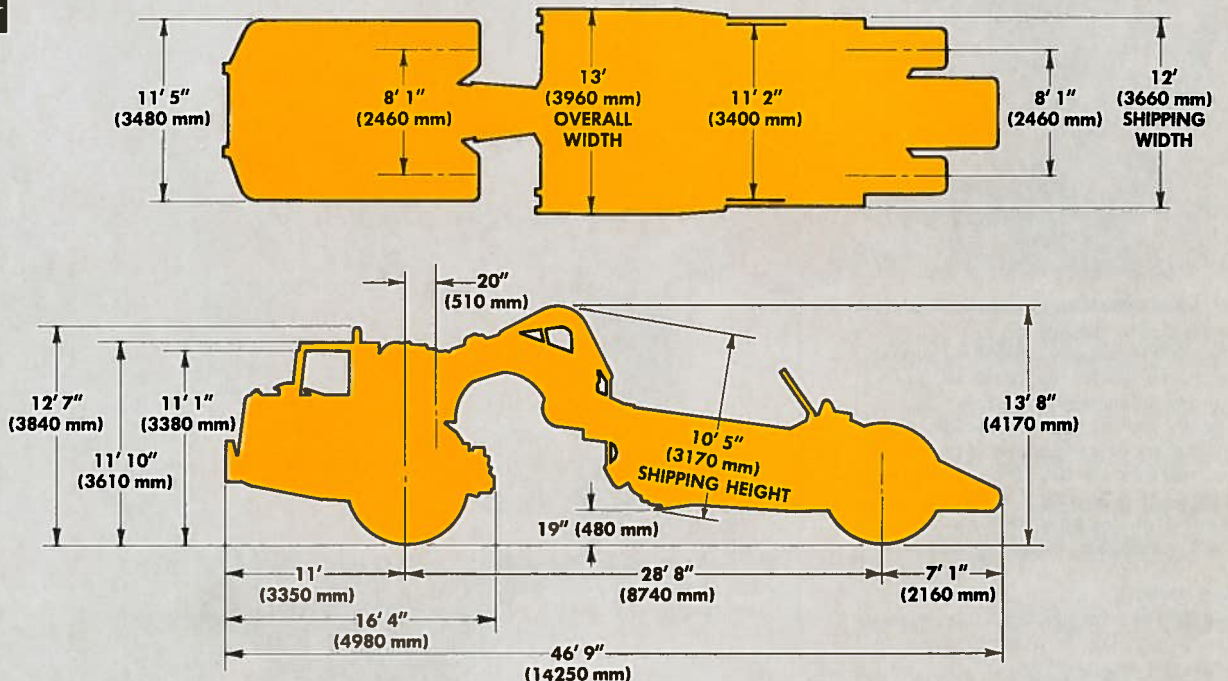



standard equipment

24-volt direct electric starting. 35-amp alternator. Two 220-amp-hour, 12-volt batteries. Suction fan. Muffler. Crankcase guard. Dry-type air cleaner with automatic dust ejector. 8-speed semiautomatic power shift transmission. Downshift inhibitor. Differential lock. Coolant flow indicator. Cushion hitch. Quick-drop bowl control valve. Combination bowl-apron control lever. Parking brake. Emergency braking system. Brake shields. Horn. ROPS canopy (U.S.A.). ROPS mounting. Hydraulically adjustable suspension seat. Seat belt. Operator's station with vibration isolators. Electric hour meter. Windshield wiper. Dash lights. Headlights. Rear-mounted floodlight. Vandalism protection group. Ether starting aid. Backup alarm.



optional equipment

(with approximate installed weights)

	Lb	Kg
Air conditioner/heater (includes 50-amp alternator)	262	119
Alternator, 50-amp	11	5
Cab, ROPS, sound suppressed	825	374
Canopy, ROPS (standard in U.S.A.)	600	272
Cutting edges,		
Special application, three section (stinger and ends)		
1-3/8"/349 mm	218	99
Special application, three section (stinger and ends)		
1-5/8"/413 mm	407	185
Three section (stinger and ends) 1-5/8"/413 mm	138	63
Special application (provides level cut)		
1-5/8"/413 mm	378	171
Fast-fill fuel system, automatic	7	3
Fast oil change system	10	5
Fenders, scraper	340	154
Heater, cab, roof-mounted	212	96
Heater, engine coolant	5	2
Hood door, right side	22	10
Power train guard	340	154
Retarder, hydraulic	371	168
Starting receptacle	20	9
Supplemental steering system	225	102
Throttle lock	14	6
Tires, set of two, tractor and scraper:		
37.25-35, 30 PR (E-3)	490	222
33.25-35, radial steel cord	124	56
33.25-35, radial steel cord	-470	-213
Tool kit	23	10
Travel brackets	550	249

gradeability/speed/rimpull

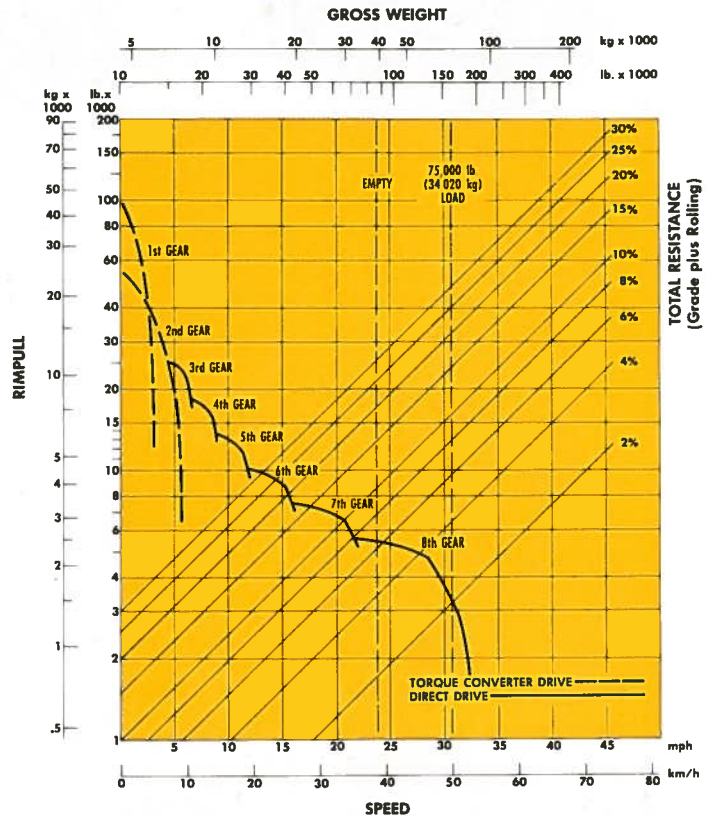

To determine gradeability performance: Read from gross weight down to % of total resistance. (Total resistance equals actual % grade plus 1% for each 20 lb./ton/10 kg/t of rolling resistance.) From this weight-resistance point, read horizontally to the curve with the highest obtainable speed range, then down to maximum speed. Usable rimpull depends upon traction available and weight on drive wheels.

Materials and specifications are subject to change without notice.